

ADS N-12[®] WT IB PIPE (per AASHTO) SPECIFICATION

Scope

This specification describes 4- through 60-inch (100 to 1500 mm) ADS N-12 WT IB pipe (per AASHTO) for use in gravity-flow applications.

Pipe Requirements

N-12 WT IB pipe (per AASHTO) shall have a smooth interior and annular exterior corrugations.

- 4- through 10-inch (100 to 250 mm) shall meet AASHTO M252, Type S.
- 12- through 60-inch (300 to 1500 mm) shall meet AASHTO M294, Type S or ASTM F2306.
- Manning's "n" value for use in design shall be 0.012.

Joint Performance

Pipe shall be joined with the N-12 WT IB joint meeting the requirements of AASHTO M252, AASHTO M294, or ASTM F2306.

4- through 60-inch (100 to 1500 mm) shall be watertight according to the requirements of ASTM D3212. Gaskets shall meet the requirements of ASTM F477. Gaskets shall be installed by the pipe manufacturer and covered with a removable, protective wrap to ensure the gasket is free from debris. A joint lubricant available from the manufacturer shall be used on the gasket and bell during assembly.

12- through 60-inch (300 to 1500 mm) diameters shall have a reinforced bell with a polymer composite band. The bell tolerance device shall be installed by the manufacturer.

Fittings

Fittings shall conform to AASHTO M252, AASHTO M294, or ASTM F2306. Bell and spigot connections shall utilize a spun-on or welded bell and valley or saddle gasket meeting the watertight joint performance requirements of AASHTO M252, AASHTO M294 or ASTM F2306.

Field Pipe and Joint Performance

To assure watertightness, field performance verification may be accomplished by testing in accordance with ASTM F2487. Appropriate safety precautions must be used when field-testing any pipe material. Contact the manufacturer for recommended leakage rates.

Material Properties

Virgin material for pipe and fitting production shall be high-density polyethylene conforming with the minimum requirements of cell classification 424420C for 4- through 10-inch (100 to 250 mm) diameters, and 435400C for 12- through 60-inch (300 to 1500 mm) diameters, as defined and described in the latest version of ASTM D3350, except that carbon black content should not exceed 4%. The 12- through 60-inch (300 to 1500 mm) virgin pipe material shall comply with the notched constant ligament-stress (NCLS) test as specified in Sections 9.5 and 5.1 of AASHTO M294 and ASTM F2306 respectively.

Installation

Installation shall be in accordance with ASTM D2321 and ADS recommended installation guidelines, with the exception that minimum cover in trafficked areas for 4- through 48-inch (100 to 1200 mm) diameters shall be one foot. (0.3 m) and for 54- and 60-inch (1350 and 1500 mm) diameters, the minimum cover shall be 2 ft. (0.6 m) in single run applications. Backfill for minimum cover situations shall consist of Class 1, Class 2 (minimum 90% SPD) or Class 3 (minimum 90%) material. Maximum fill heights depend on embedment material and compaction level; please refer to Technical Note 2.01. Contact your local ADS representative or visit our website at www.ads-pipe.com for a copy of the latest installation guidelines.

Pipe Dimensions

	Nominal Diameter, in (mm)													
Pipe I.D. in (mm)	4 (100)	6 (150)	8 (200)	10 (250)	12 (300)	15 (375)	18 (450)	24 (600)	30 (750)	36 (900)	42 (1050)	48 (1200)	54* (1350)	60 (1500)
Pipe O.D.** in (mm)	4.8 (122)	6.9 (175)	9.1 (231)	11.4 (290)	14.5 (368)	18 (457)	22 (559)	28 (711)	36 (914)	42 (1067)	48 (1219)	54 (1372)	61 (1549)	67 (1702)
Perforations	All diameters available with or without perforations													

*Check with sales representative for availability by region.

**Pipe O.D. values are provided for reference purposes only, values stated for 12- through 60-inch are ± 1 inch. Contact a sales representative for exact values.

N-12[®] WT IB (per AASHTO) JOINT SYSTEM

(Joint configuration & availability subject to change without notice. Product detail may differ slightly from actual product appearance.)

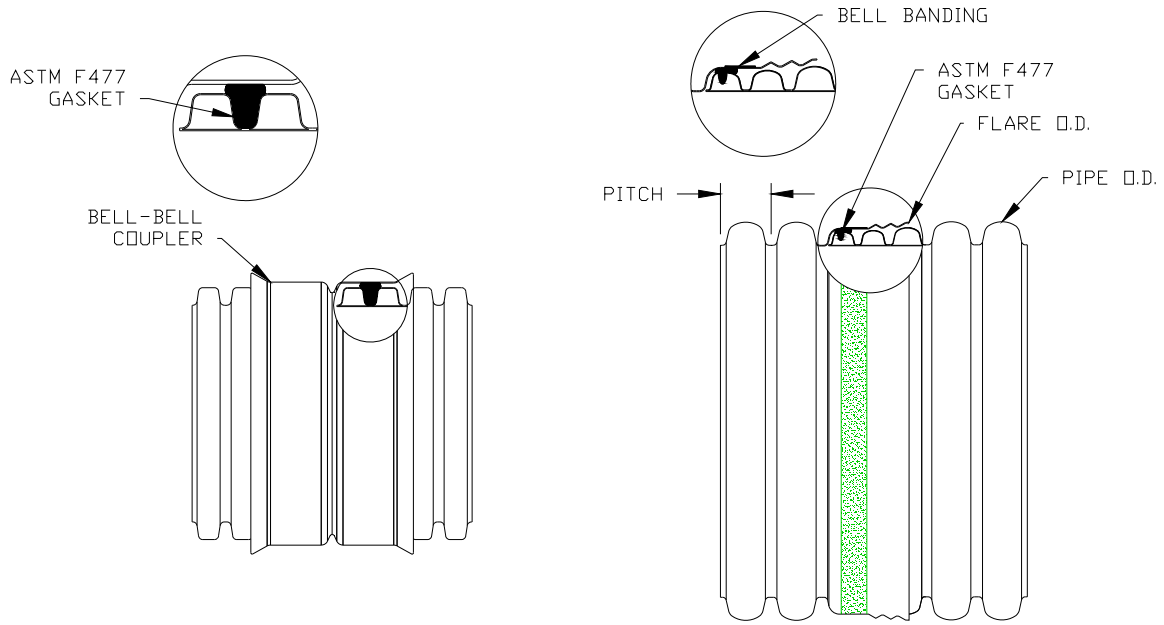

4" - 10"
(100-250 MM)

12" - 60"
(300-1500 MM)

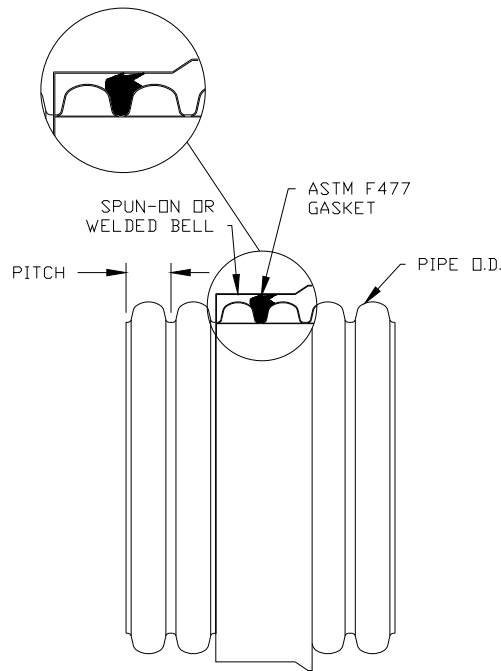

12" - 60"
(300-1500 MM)